

- Ergonomic cushion-grip handle-Insulates against cold temperature in the hand, helps ease user fatigue, and insulates against vibration.
- Power/Speed Regulator-Allows for easy RPM adjustment.
- Rear exhaust-Directs the exhaust away from the user and the working areas.
- Twin-Bearing Spindle-This quality design results in super precise spindle concentricity less than 0.05mm and minimal vibration.

ZDG-2319 0.3HP (7,600RPM)

Medium Speed Mini Air Die Grinder

- Low profile for grinding restricted areas.
- Light weight for fatigue free use.
- Medium speed for specific grinding accessories.



ZDG-231AL 0.3HP

3" Extension Mini Air Die Grinder



ZDG-231L 0.3HP

5" Extension Mini Air Die Grinder



ZDG-231 0.3HP

Mini Air Die Grinder

- The ZDG-231 Mini Die Grinder is suitable for light weld grinding, porting and polishing applications. It features a spindle concentricity less than 0.05mm.



ZDG-231K 0.3HP

Mini Die Grinder Tool Kit

Specifications:

- 1PC Die Grinder
- 2PCS Spanners
- 5PCS 1/4" Shank Grinding Stones
- 5PCS 1/8" Shank Grinding Stones
- 1PC 1/8" Collet
- 1PC Nipple
- 1PC Blow Case



ZDG-236 0.3HP

Mini Air Angle Die Grinder

- The ZDG-236 Mini Angle Die Grinder allows easy handling in confined areas, and is capable of using carbide burs and other attachments for polishing, porting, and light metal removal.



ZDG-236K 0.3HP

Mini Angle Die Grinder Tool Kit

Specifications:

- 1PC Angle Die Grinder
- 1PC 2" Roloc Pad
- 5PCS 2" Roloc Scotch Discs
- 1PC 1/8" Collet
- 1PC Nipple
- 2PCS Spanners
- 5PCS 1/8" Shank Grinding Stones
- 5PCS 1/4" Shank Grinding Stones
- 1PC Blow Case



Model	Collet Size in.(mm)	Net Weight lbs(kgs)	Length in.(mm)	RPM	Air Inlet Size inch-NPT/PT	Min. Hose Size inch(mm)	Avg. Air Consumption cfm
ZDG-231	1/4(6)	0.9(0.4)	6.1(155)	25,000	1/4	3/8(10)	3
ZDG-236	1/4(6)	1.1(0.5)	6.1(155)	20,000	1/4	3/8(10)	3
ZDG-2319	1/4(6)	1.3(0.6)	7.3(185)	7,600	1/4	3/8(10)	3
ZDG-231AL	1/4(6)	1.3(0.5)	8.6(220)	25,000	1/4	3/8(10)	2.6
ZDG-231L	1/4(6)	1.5(0.7)	10.1(259)	25,000	1/4	3/8(10)	2.6



ZDG-S215 0.3HP

Industrial 1/4" Air Die Grinder



ZDG-S24B 0.3HP

Industrial 1/4" Air Die Grinder

- High power, efficient motor for heavy grinding works.
- Side exhaust.
- Roll type throttle.
- Compact and durable steel housing for long service life.

Model	Size of Collet inch(mm)	Free Speed R.P.M.	Operating Air Pressure PSI(bar)	Avg. Air Consumption cfm(l/min)	Net Weight lbs(kgs)	Overall Length inch(mm)	Min. Hose Size inch(mm)	Air Inlet Size inch-NPT/PT
ZDG-S215	1/4(6)	24,000	90(6.2)	7.8(220)	1.46(0.66)	6-11/16(170)	3/8(10)	1/4
ZDG-S24B	1/4(6)	24,000	90(6.2)	7.8(220)	1.7(0.77)	7-3/64(179)	3/8(10)	1/4



ZAG213A 0.3HP

Air Angle Grinder



ZAG213B 0.3HP

Air Angle Grinder



ZAG213AF 0.3HP

Air Angle Grinder



ZAG213BF 0.3HP

Air Angle Grinder

Model	Grinding Wheel inch(mm)	Free Speed R.P.M.	Operating Air Pressure PSI(bar)	Avg. Air Consumption cfm(l/min)	Net Weight lbs(kgs)	Overall Length inch(mm)	Min. Hose Size inch(mm)	Air Inlet Size inch-NPT/PT
ZAG213A	2(50)	15,000	90(6.2)	7.8(220)	1.46(0.66)	6-3/16(157)	3/8(10)	1/4
ZAG213B	2(50)	15,000	90(6.2)	6.7(190)	1.64(0.74)	7-13/32(188)	3/8(10)	1/4
ZAG213AF	1/4(6)	15,000	90(6.2)	7.8(220)	1.44(0.65)	6-3/16(157)	3/8(10)	1/4
ZAG213BF	1/4(6)	15,000	90(6.2)	6.7(190)	1.61(0.73)	7-13/32(188)	3/8(10)	1/4

ZP313 0.5HP

Air Die Grinder

- The ZP313 Die Grinder is suitable for Many automotive and industrial high speed grinding applications. The grinder can be used to clean dies, rotors, backing plates and brake pad mounts.
- Grind valve seats, dress welds and enlarge holes.
- Can use with 1/4"(6mm) or 1/8"(3mm) grinding accessories.



ZP313K 0.5HP

Air Die Grinder Tool Kit

- Specifications:
- 1PC Die Grinder
 - 2PCS Spanners
 - 5PCS 1/4" Shank Grinding Stones
 - 5PCS 1/8" Shank Grinding Stones
 - 1PC 1/8" Collet
 - 1PC Nipple
 - 1PC Blow Case



ZDG-356A 0.5HP (2,600RPM)

ZDG-376A 0.5HP (3,600RPM)

Low Speed Air Die Grinder

- In-Line Die Grinder is designed for low speed application.
- Can use with 1/4"(6mm) or 1/8"(3mm) grinding accessories.



ZDG-376AL 0.5HP (3,600RPM)

Low Speed Air Extension Die Grinder

- The die grinder come with 1/4"(6mm) or 3/8"(8mm) double angle collets for industrial application.

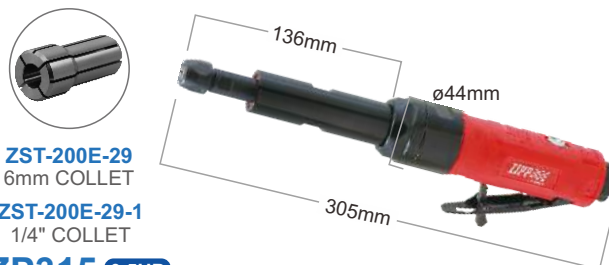

ZST-200E-29
6mm COLLET

ZST-200E-29-1
1/4" COLLET

ZP314 0.5HP

3" Air Extension Die Grinder

- Extension Die Grinder is designed for high speed grinding and polishing in hard-to-reach areas.
- Features an extended reach of 3".
- By using 1/4"(6mm) or 1/8"(3mm) grinding accessories, the grinder can be used in a wide range of grinding and polishing applications.



ZP315 0.5HP

5" Air Extension Die Grinder

- Extension Die Grinder is designed for high speed grinding and polishing in hard-to-reach areas.
- Features an extended reach of 5".
- By using 1/4"(6mm) or 1/8"(3mm) grinding accessories, the grinder can be used in a wide range of grinding and polishing applications.



ZP319 0.5HP

Air Angle Die Grinder

- The ZP319 Angle Die Grinder is ideal for high speed grinding and polishing.
- It can be used in finishing dies and metal molds, smoothing and shaping sheet metal and cast iron, weld finishing and other high speed polishing applications.
- Can use with 1/4"(6mm) or 1/8"(3mm) grinding accessories.

ZP319K 0.5HP

Angle Die Grinder Tool Kit

- Specifications:
- 1PC Angle Die Grinder
 - 5PCS 2" Roloc Scotch Discs
 - 5PCS 3" Roloc Scotch Discs
 - 1PC 1/8" Collet
 - 1PC Nipple
 - 2PCS Spanners
 - 5PCS 1/8" Shank Grinding Stones
 - 5PCS 1/4" Shank Grinding Stones
 - 1PC Blow Molded Case
 - 2PCS Roloc Pad
 - 2PCS Bolts

ZDG-3226 0.5HP

115° Air Angle Die Grinder

- The ZDG-3226 Angle Die Grinder is ideal for high speed grinding and polishing.
- It can be used in finishing dies and metal molds, smoothing and shaping sheet metal and cast iron, weld finishing and other high speed polishing applications.
- Can use with 1/4"(6mm) or 1/8"(3mm) grinding accessories.



ZAG-341 0.5HP

2" Air Angle Grinder

- The Angle Grinder features versatile application for grinding, including depressed disc.



ZBT288544-2GD060
(#60Grit), 2"DISC WHEEL

Model	Collet Size inch(mm)	Net Weight lbs(kgs)	Length in.(mm)	RPM	Air Inlet Size inch-NPT/PT	Min. Hose Size inch(mm)	Avg. Air Consumption cfm
ZP313	1/4(6)	1.3(0.6)	7(178)	22,000	1/4	3/8(10)	3.7
ZDG-356A/376A	1/4(6)	1.5(0.7)	7.8(200)	2,600/3,600	1/4	3/8(10)	3.7
ZDG-376AL	1/4(6)	2.2(1)	12(305)	3,600	1/4	3/8(10)	3.5
ZP314	1/4(6)	1.5(0.7)	9.4(240)	22,000	1/4	3/8(10)	3.7
ZP315	1/4(6)	1.8(0.8)	11(280)	22,000	1/4	3/8(10)	3.7
ZP319/ZDG-3226	1/4(6)	1.5(0.7)	7(178)	18,000	1/4	3/8(10)	3.7
ZAG-341	Grinding Wheel 2"	1.5(0.7)	7(178)	15,000	1/4	3/8(10)	3.5

Super Power Air Tools

- 0.9HP and 1HP air grinders come with 1/4" (6mm) or 3/8" (8mm) double angle collets for industrial application.



ZST-200E-29
6mm COLLET

ZST-200E-29-1
1/4" COLLET



ZDG-301 **0.9HP**

Air Die Grinder

- The ZDG-301 Die Grinder is suitable for many automotive and industrial high speed grinding applications. The grinder can be used to clean dies, rotors, backing plates and brake pad mounts.
- Grind valve seats, dress welds and enlarge holes.
- Can use with 1/4"(6mm) or 1/8"(3mm) grinding accessories.



ZDG-302 **0.9HP**

Air Angle Die Grinder

- The ZDG-302 Angle Die Grinder is ideal for high speed grinding and polishing.
- It can be used in finishing dies and metal molds, smoothing and cast iron, weld finishing and other high speed polishing application.
- Can use with 1/4"(6mm) or 1/8"(3mm) grinding accessories.



ZDG-301AL **1HP**

3.5" Air Extension Die Grinder

- Extension Die Grinder is designed for high speed grinding and polishing in hard-to-reach areas.
- Features an extended reach of 3.5".
- By using 1/4"(6mm) or 1/8"(3mm) grinding accessories, the grinder can be used in a wide range of grinding and polishing applications.



ZDG-301L **1HP**

5.5" Air Extension Die Grinder

- Extension Die Grinder is designed for high speed grinding and polishing in hard-to-reach areas.
- Features an extended reach of 5.5".
- By using 1/4"(6mm) or 1/8"(3mm) grinding accessories, the grinder can be used in a wide range of grinding and polishing applications.

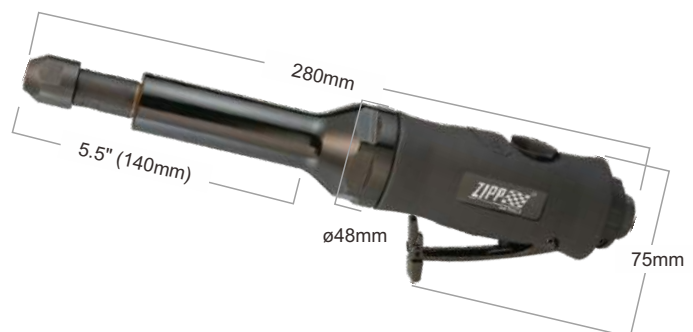

Model	Collet size inch(mm)	Net Weight lbs(kg)	Length inch(mm)	RPM	Air Inlet inch	Min.Hose Size inch(mm)	Avg. Air Cons. cfm
ZDG-301	1/4(6)	1.4(0.5)	7(180)	23,000	1/4	3/8(10)	4.1
ZDG-302	1/4(6)	1.8(0.8)	7(180)	18,000	1/4	3/8(10)	4.1
ZDG-301AL	1/4(6)	1.8(0.8)	9.4(240)	22,000	1/4	3/8(10)	4.1
ZDG-301L	1/4(6)	2(0.9)	11(280)	22,000	1/4	3/8(10)	4.1

ZDG-301L300 **1HP**

ZDG-3076L300 **1HP**

12" Air Extension Die Grinder

ZDG-301L500 **1HP**

ZDG-3076L500 **1HP**

21-3/8" Air Extension Die Grinder

ZDG-301L800 **1HP**

ZDG-3076L800 **1HP**

31-1/2" Air Extension Die Grinder



- ZST-200E-29** 6mm COLLET
- ZST-200E-29-2** 8mm COLLET
- ZST-200E-29-1** 1/4" COLLET
- ZST-200E-29-4** 3/8" COLLET

Benefits

- Industrial extended shaft long die grinder design for high speed grinding & polishing in hard-to-reach areas
- By using 1/4" (6mm) or 3/8" (8mm) Double Angle Collets, the die grinder can be used in a wide range of grinding and polishing applications with various wheels
- 4000rpm models are excellent for grinding applications with flap sanding wheel
- High productivity
- Highest durability in demanding applications

Features

- 12" (305 mm), 21-3/8" (543 mm), 31-1/2" (800 mm) extended body by Aluminum alloy structure.
- Comfort grip over-housing
- Streamlined safety lever
- Rear exhaust
- 1/4" (6mm) & 3/8" (8mm) industrial grade Double Angle collet holder
- 1.0 hp motor
- 22,000 rpm free speed models and 3,500 rpm free speed models

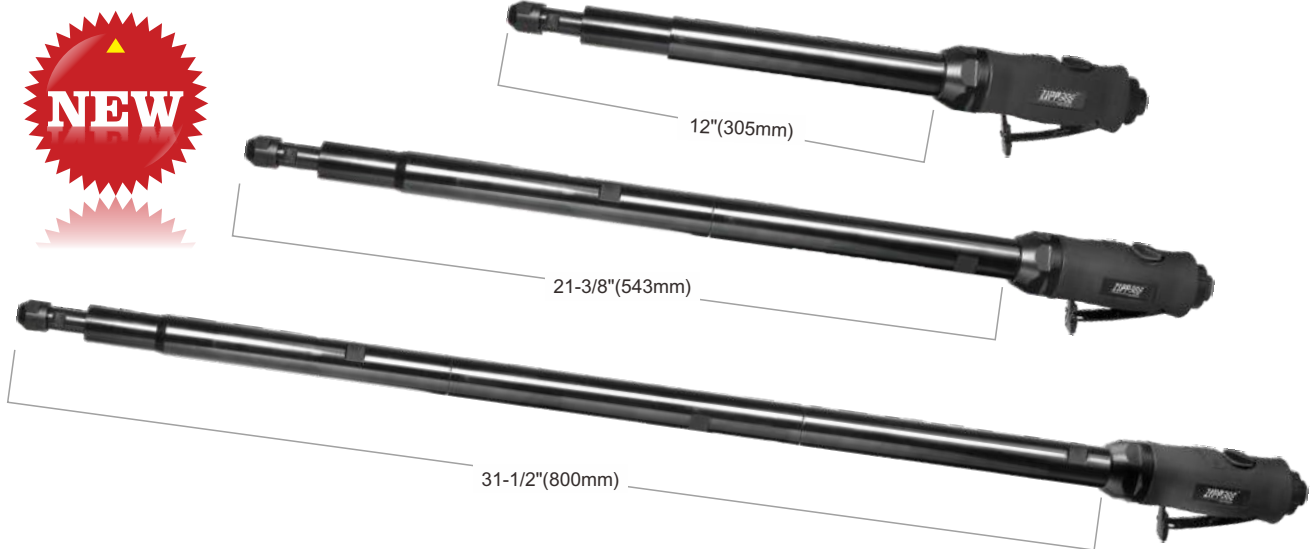

* The length of extended body can be customize to extended as requirement.

Model	Collet size inch(mm)	Net Weight lbs(kg)	Length inch(mm)	RPM	Air Inlet inch	Min.Hose Size inch(mm)	Avg. Air Cons. cfm
ZDG-301L300	1/4(6)	2.9(1.3)	17.5(445)	22,000	1/4	3/8(10)	4.2
ZDG-301L500	1/4(6)	3.9(1.8)	27(688)	22,000	1/4	3/8(10)	4.2
ZDG-301L800	1/4(6)	4.9(2.2)	37.1(943)	22,000	1/4	3/8(10)	4.2
ZDG-3076L300	1/4(6)	3.5(1.6)	18.7(477)	3,500	1/4	3/8(10)	4.2
ZDG-3076L500	1/4(6)	4.5(2)	28.3(719)	3,500	1/4	3/8(10)	4.2
ZDG-3076L800	1/4(6)	5.5(2.5)	38.3(974)	3,500	1/4	3/8(10)	4.2



ZDG-S220 0.8HP

Industrial 1/4" Air Die Grinder

- Can be used as sander for expandable / flap wheels, brushes.



ZDG-S216 0.8HP

Industrial 1/4" Air Die Grinder

- With 360° rotating rear exhaust muffler Safety Trigger.
- Use for heavy grinding works.



ZDG-S206 0.8HP

Industrial 1/4" Air Die Grinder

- Can be used as sander for expandable / flap wheels, brushes.



ZDG-S235 0.8HP

Industrial 1/4" Air Die Grinder

- Can be used as sander for expandable / flap wheels, brushes.



P/N:
24182-10 3/8"-24
24182-13 1/2"-20

Optional combo arbor (interchange with # 24182 arbor set) with 1/2"-20 or 3/8"-24 female thread for up to 3" wide wheels with 5/8" or 1" diameter center hole for use on model# **ZDG-S220**, **ZDG-S206** & **ZDG-S235** grinders.

Model	Size of Collet inch(mm)	Free Speed R.P.M.	Operating Air Pressure PSI(bar)	Avg. Air Consumption cfm(l/min)	Net Weight lbs(kgs)	Overall Length inch(mm)	Min. Hose Size inch(mm)	Air Inlet Size inch-NPT/PT
ZDG-S220	1/4(6)	2,200	90(6.2)	5(141)	2(0.92)	8-5/8(220)	3/8(10)	1/4
ZDG-S216	1/4(6)	15,000	90(6.2)	5(141)	1.8(0.8)	8(200)	3/8(10)	1/4
ZDG-S206	1/4(6)	600	90(6.2)	5(141)	2.6(1.2)	10(250)	3/8(10)	1/4
ZDG-S235	1/4(6)	3,500	90(6.2)	5(141)	2(0.92)	8-5/8(220)	3/8(10)	1/4